

Sanitary Pressure / Differential Pressure Transmitter

Core Definition

A sanitary pressure / differential pressure transmitter is an industrial measuring instrument that meets sanitary-grade requirements in food, beverage, pharmaceutical, biomedical and other applications. It is used to measure the pressure or differential pressure of fluid media and convert them into standard electrical signals (such as 4~20mA, HART, PROFIBUS-PA, etc.) for output.

Sanitary Design

- **Safe Materials:** Wetted parts including the diaphragm are made of food-grade / pharmaceutical-grade materials such as 316L stainless steel, Hastelloy C, or 316 stainless steel for other wetted components, free from heavy-metal precipitation and compliant with FDA certification.
- **No Dead Zones:** Designed with a cavity-free / smooth chamber structure. Sensor surface polishing achieves $Ra \leq 0.8 \mu\text{m}$ (mirror finish), and can reach up to $Ra < 0.38 \mu\text{m}$ (15 μin). No recesses or gaps to prevent medium residue and bacterial growth.
- **Easy-to-Clean Compatibility:** Supports CIP (Clean-in-Place) and SIP (Sterilize-in-Place) processes. Withstands high temperatures (e.g., 150°C steam) and chemical cleaning agents with no residue after cleaning.
- **Compliant Sealing:** Equipped with sanitary gaskets – VMQ (standard), EPDM, or customer-specified materials. Odorless, non-swelling, and prevents medium leakage or gasket contamination.
- **Standardized Connections:** Uses sanitary quick-fit connections (clamp, sanitary threaded, etc.) for easy assembly and disassembly, enabling fast maintenance and cleaning to meet rapid production line changeover requirements.

Core Advantages

- **High-Precision Measurement:** Measuring accuracy of $\pm 0.1\%$ FS, up to $\pm 0.075\%$ FS, capable of detecting tiny pressure fluctuations in applications such as pharmaceutical liquid delivery and food filling.
- **Safety & Compliance:** The transmitter fully complies with industry standards including 3-A (food machinery), EHEDG (European Hygienic Engineering & Design Group), and GMP (Good Manufacturing Practice), and is certified to 3-A Sanitary Standards.

Applications

- **Food & Beverage:** Pressure monitoring in dairy fermentation tanks, juice filling lines, and beer brewing pipelines (avoids material contamination and supports CIP cleaning).

- **Pharmaceutical & Biotechnology:** Pressure measurement in pharmaceutical storage tanks, infusion pipelines, and bioreactors (fermenters) (GMP-compliant, supports SIP sterilization, prevents cross-contamination).
- **Daily Chemical Industry:** Pressure monitoring in cosmetic emulsion mixing tanks and sterile laundry detergent production equipment (non-toxic materials, no hygienic dead zones).
- **Drinking Water Treatment:** Pressure measurement in pure and mineral water pipelines (ensures water quality is unaffected by equipment materials).

WP-8 / K1 / AK Series Sanitary Pressure Transmitter

The WP-8/K1/AK series sanitary pressure transmitters are assembled using internationally advanced sensors combined with high-precision electronic components through strict manufacturing processes. By fully utilizing the technical advantages of the sensors, the WP series general sanitary pressure transmitters deliver excellent technical performance. It features strong overload and impact resistance, low temperature drift, high stability, and high measurement accuracy. The pressure sensor adopted by this series is an all-welded stainless steel body, equipped with a built-in solid-state pressure sensitive chip and a stainless steel isolating diaphragm, with the interior of the steel body filled with sanitary oil. The measured pressure acts on the diaphragm and is transmitted to the sensitive chip through the sanitary oil. The sensitive chip is connected to the transmitter's dedicated amplifier circuit via wires; it utilizes the piezoresistive effect of semiconductor silicon material to realize the conversion between pressure and electrical signals. Since the electrical signal output by the Wheatstone bridge on the sensitive chip has a good linear relationship with the applied pressure, accurate pressure measurement can be achieved.

Key Features

- Strong overload and shock resistance
- High stability: better than 0.1% FS per year
- Strong anti-interference capability: waterproof, dustproof, shockproof, explosion-proof and corrosion-resistant
- Wide applicability: various models, process connections and wetted materials available for various measurement scenarios
- Easy installation: reasonable structure, compact size, light weight, and can be mounted directly in any position

Technical Specifications

- Pressure type: gauge pressure, absolute pressure, sealed gauge pressure
- Range: -0.1MPa ~ 0kPa ~ 10kPa ... 3MPa
- Supply voltage: 12.5 ~ 36 V DC
- Output signal: 4~20 mA DC / 4~20 mA DC + HART / 4~20 mA DC + RS485 communication
- Diaphragm material: 316L stainless steel or Hastelloy C
- Other wetted parts: 316L stainless steel
- Wetted surface finish: compliant with 3-A sanitary standards; $R_a < 0.8 \mu\text{m}$ (31.5 μin), up to $R_a < 0.38 \mu\text{m}$ (15 μin)
- Fill fluid: sanitary oil (NEOBEE M-20)
- Process medium temperature: -10 ~ +70 °C; -10 ~ +120 °C with heat sink
- Cleaning temperature: 150 °C, max. 30 minutes
- Accuracy: Class 0.2, Class 0.5
- Process connection: clamp, flush diaphragm and other global or industrial standard connections

- Seals: FDA-compliant seals, VMQ (standard), EPDM or customer-specified
- Housing material / electrical connection:
 - Die-cast aluminum / NPT1/2 internal thread or M20×1.5 internal thread
 - 304 stainless steel / M12×1 4-pin aviation connector or Hirschmann connector
- Certification: 3-A Sanitary Standards certified
- Temperature limits:
 - Ambient: -20 ~ 70 °C
 - Storage: -20 ~ 80 °C
- Effect of ambient temperature variation: $\pm 0.15\%$ FS / 10 °C

Process Connection

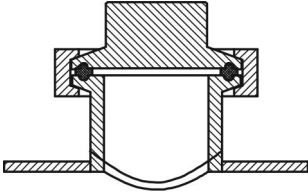
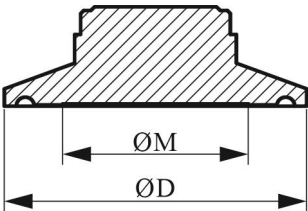
Clamp Connection (P1/P2)		
Installation Drawing		
		
Dimension Drawing		
		
Specification	Dimension ΦD mm	Corrugated Dimension ΦM mm
1-1/2"	50.5	31
2"	64	42
Measuring Range	Gauge Pressure	-0.1~1.6MPa
	Absolute Pressure	0~1.6MPa
	Differential Pressure	0-10kPa~1MPa

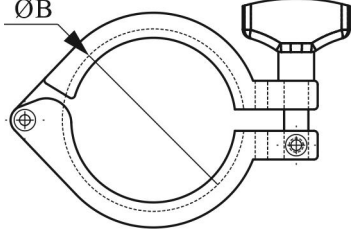
Clamp Collar (Unit: mm)	
	
Specification	Dimension (ΦB)
1-1/2"	53.9
2"	67.4

Seal Ring (Unit: mm)		
		
Specification	Dimension (ΦD)	Dimension (ΦA)
1-1/2"	50.5	35.8
2"	64	47.8

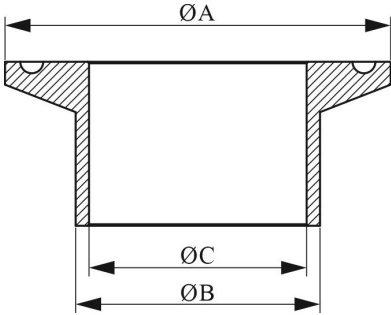
Welded Adapter (Unit: mm)			
			
Specification	Dimension (ΦA)	Dimension (ΦB)	Dimension (ΦC)
1-1/2"	50.5	38	35.6
2"	64	51	48.6

Flush Diaphragm (P3/P4)

Installation Drawing

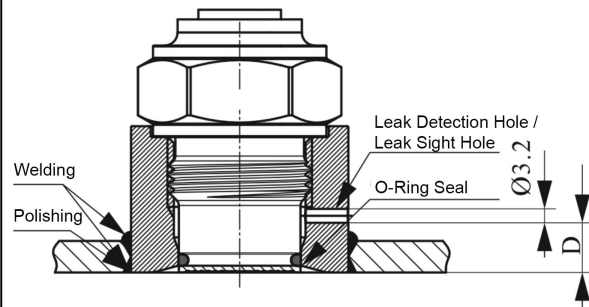

Dimension Drawing

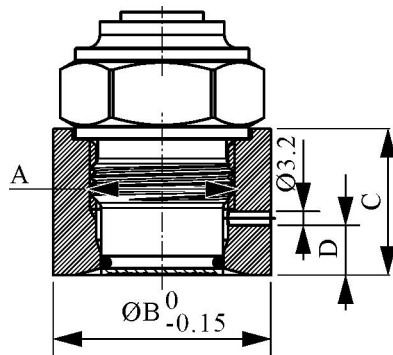





Specification	Outer Diameter of Welding Hub ΦB mm	Height of Weld Hub C mm	Sight Hole Position D mm
G1/2	40	20	5.5
M20×1.5	40	19	5.5
Measuring Range	Gauge Pressure	-0.1~3MPa	
	Absolute Pressure	0~3MPa	

WP Series Pressure Transmitter Standard Range Table

G03		0~10kPa
G04		0~16kPa
G05	A1	0~20kPa
G06	A2	0~25kPa
G07	A3	0~30kPa
G08	A4	0~35kPa
G09	A5	0~40kPa
G10	A6	0~60kPa
G11	A7	0~100kPa
G12	A8	0~160kPa
G13	A9	0~200kPa
G14	A10	0~250kPa
G15	A11	0~400kPa
G16	A12	0~600kPa
G17	A13	0~1000kPa
G18	A14	0~1600kPa
G19	A15	0~2000kPa
G20	A16	0~2500kPa
G21	A17	0~3000kPa
G30		-10~10kPa
G31		-20~20kPa
G32		-50~50kPa
G33		-100~60kPa
G34		-100~100kPa
G35		-100~150kPa
G36		-100~300kPa
G37		-100~500kPa
G38		-100~900kPa
G39		-100~1500kPa
G40		-100~2000kPa

Non-wetted Parts

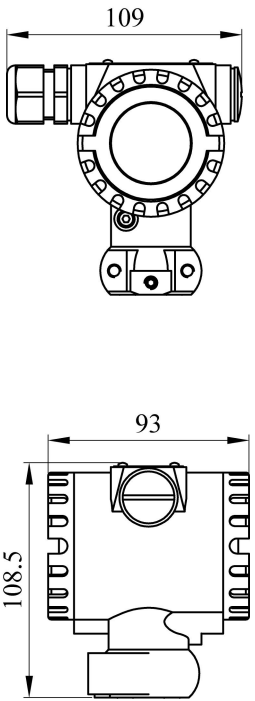
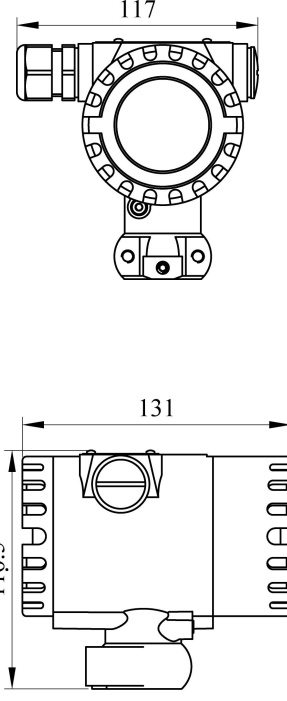
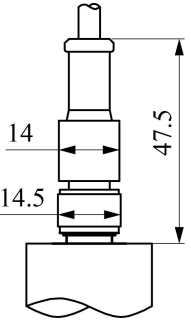
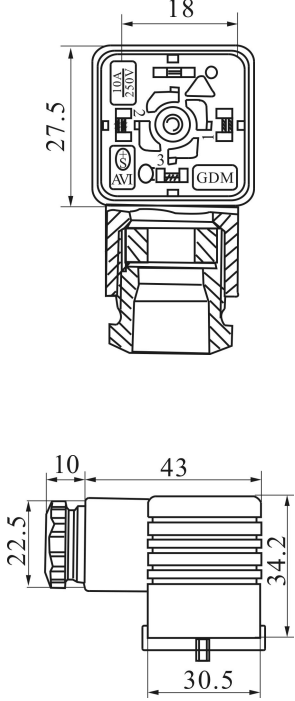
	K1	AK	8 Series Aviation Connector	8 Series Hirschmann Connector
Picture				
Dimension Drawing				

Wiring Diagram								
	Terminal Block				Wiring Definition for Aviation Plug Connection		Pin Definition for Hirschmann Connector Connection	
	DC24V (4~20) mA±	Power Supply & Output	1/Red	Power +	Pin	2-Wire		
	TEST±	External Ammeter Test Terminal (Impedance < 10 Ω)	2/Black	Power -	1	Power +		
			3/Blue	Grounding	2	Power -		
⊥	Earth Terminal	Ground	4	NC	3	NC		
Electrical Connection	NPT 1/2 Internal Thread, M20×1.5 Internal Thread			M12×1 4-Pin Aviation Connector				
Protection Rating	IP65							
Fill Fluid	Sanitary Oil (NEOBEE M-20)							

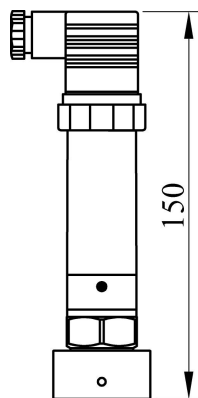

Hirschmann connector, no display, flush diaphragm

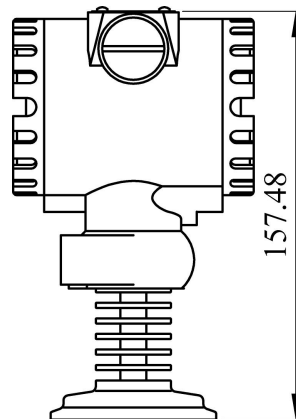

Aluminum housing, no display, clamp connection

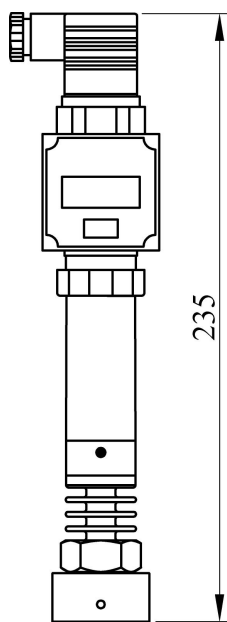

Hirschmann connector, with display, with heat dissipation, flush diaphragm

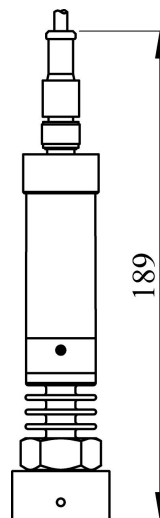

Aviation connector, no display, with heat dissipation, flush diaphragm

Overall dimensions (Unit: mm)

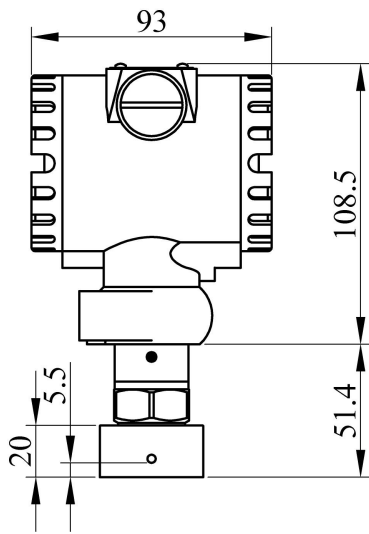

K1 aluminum housing, no display, flush diaphragm

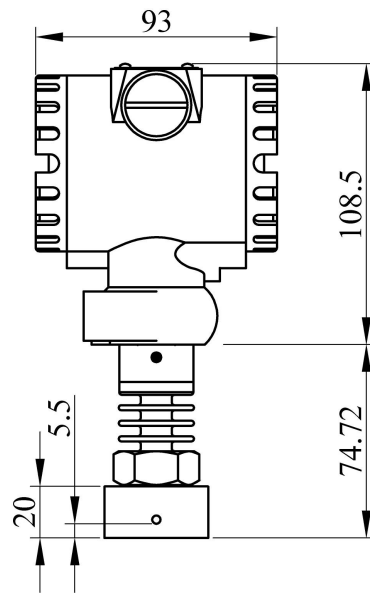

K1 aluminum housing, no display, with heat dissipation, flush diaphragm

Overall dimensions (Unit: mm)

WP-8 / K1 / AK Sanitary Pressure Transmitter

Model	Transmitter Type	
WP-8-	Sanitary Pressure Transmitter (Compact Type)	
WP-K1-	Sanitary Pressure Transmitter	
WP-AK-	Sanitary Pressure Transmitter (Smart Type)	
Code	Fill Fluid	Diaphragm Material
HA	Sanitary Oil	316L Stainless Steel
HB	Sanitary Oil	Hastelloy C
Code	Process Connection Material	
1	316L Stainless Steel	
Code	Signal Output Mode	
E	(4~20)mA DC 2-wire (For Series 8 & K1)	
I	Smart (4~20)mA DC 2-wire with HART Protocol (For Series AK)	
S	(4~20)mA + 485 Communication (Modbus-RTU)	
Code	Process Connection	
P1	Clamp Type (1.5") Φ 50.5mm	
P2	Clamp Type (2") Φ 64mm	
P3	Flush Diaphragm, G1/2 Male Thread	
P4	Flush Diaphragm, M20 \times 1.5 Male Thread	
Code	Explosion-proof Grade	
S	Standard (Non-explosion-proof)	
Code	Display Mode	
A	No Local Indicator	
C	LCD Display (Not Applicable for Aviation Connector)	
Code	Accuracy Class	
2	Class 0.2	
5	Class 0.5	
Code	Measuring Range	
<input type="checkbox"/>	Standard Range List	
Code	Pressure Type	
G	Gauge Pressure	
A	Absolute Pressure	

Code	Electrical Interface
A	NPT1/2 Female Thread, Aluminum Housing (For Series K1 / AK)
M	M20×1.5 Female Thread, Aluminum Housing (For Series K1 / AK)
J	M12×1 Aviation Connector, Stainless Steel Housing (For Series 8)
J1	Hirschmann Connector, Stainless Steel Housing (For Series 8)
Code	Other Options
R	Heat Sink
Y	Special Function (Please Contact Our Company When Ordering)